

# LED BLINDER

## WHITE

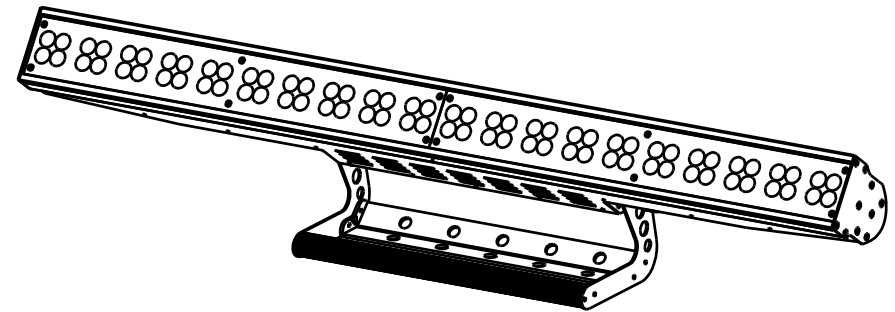

## Operation Manual

Other languages (FR + NL + DU + ES + PT)  
can be downloaded from:  
[WWW.BRITEQ-LIGHTING.COM](http://WWW.BRITEQ-LIGHTING.COM)

[WWW.BRITEQ-LIGHTING.COM](http://WWW.BRITEQ-LIGHTING.COM)

Copyright © 2010 by BEGLEC NV

't Hofveld 2C ~ B1702 Groot-Bijgaarden ~ Belgium

Reproduction or publication of the content in any manner, without express permission of the publisher, is prohibited.



Version: 1.0



# DANGER ~ GEVAAR ~ GEFAHR ~ PELIGRO ~ PERIGO

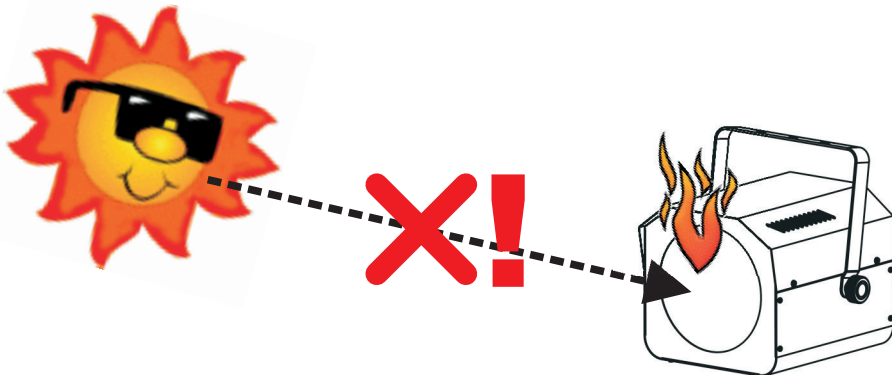

**WARNING: DANGER!** never expose the lens to direct sunlight, even for a short period. This may damage the light effect or even cause fire!

**ATTENTION: DANGER!** n'exposez jamais la lentille directement aux rayons de soleil, même pendant un bref instant. Ceci peut endommager l'intérieur de l'appareil ou même causer un incendie !

**OPGELET : GEVAAR !** stel de lens nooit bloot aan direct zonlicht, zelfs gedurende een korte periode. Dit kan het toestel beschadigen en zelfs brand veroorzaken!

**WARNUNG: GEFAHR!** Setzen sie die Linse niemals direkter Sonneneinstrahlung aus, auch nicht für eine kurze Zeit ! Die direkte Sonneneinstrahlung kann das Gerät zerstören oder zum brennen bringen!

**ADVERTENCIA: ¡PELIGRO!** ¡nunca exponga la lente a la luz solar directa, aún durante un período corto! ¡Esto puede dañar el efecto de luz o incluso causar el fuego!

**AVISO: PERIGO!** Nunca exponha as lentes directamente à luz solar, mesmo que por pouco tempo! Isto pode danificar o efeito luminoso ou mesmo provocar um incêndio!

---

## EN - DISPOSAL OF THE DEVICE

Dispose of the unit and used batteries in an environment friendly manner according to your country regulations.

## FR - DÉCLASSER L'APPAREIL

Débarrassez-vous de l'appareil et des piles usagées de manière écologique, conformément aux dispositions légales de votre pays.

## NL - VERWIJDEREN VAN HET APPARAAT

Verwijder het toestel en de gebruikte batterijen op een milieuvriendelijke manier conform de in uw land geldende voorschriften.

## DU - ENTSORGUNG DES GERÄTS

Entsorgen Sie das Gerät und die Batterien auf umweltfreundliche Art und Weise gemäß den Vorschriften Ihres Landes.

## ES - DESHACERSE DEL APARATO

Reciclar el aparato y pilas usadas de forma ecologica conforme a las disposiciones legales de su país.

## PT - COMO DESFAZER-SE DA UNIDADE

Tente reciclar a unidade e as pilhas usadas respeitando o ambiente e em conformidade com as normas vigentes no seu país.



# OPERATION MANUAL

Thank you for buying this Briteq® product. To take full advantage of all possibilities and for your own safety, please read these operating instructions very carefully before you start using this unit.

## FEATURES

This unit is radio-interference suppressed. This product meets the requirements of the current European and national guidelines. Conformity has been established and the relevant statements and documents have been deposited by the manufacturer.

- This device was designed to produce decorative effect lighting and is used in light show systems.
- No more expensive, halogen lamps with extremely short lifetime: this powerful LED Blinder is the future!
- Equipped with 40 high power 1Watt LEDs, distributed over 10 independent clusters
- Each LED-cluster is fully controllable by DMX for endless possibilities!
- Different preprogrammed shows: random, audio controlled, falling star, line chases, fading effects, 10x10 matrix programs (for 10units), ...
- Different operation modes:
  - DMX 1ch: 1fader for combined dimmer, sound active, strobe and full-on function on all clusters.
  - DMX 2ch: dimmer + different strobe functions on all clusters.
  - DMX 4MSL: DMX master/slave: choose from a selection of internal chases + chase/strobe speed & dim
  - DMX 10ch: dimmer control for individual clusters
  - DMX 12ch: dimmer control for individual clusters + master strobe function + master dimmer
  - Standalone with optional hand controller
- Perfect for use in TV-studios thanks to the 400Hz dimmer electronics!
- Very narrow 15° beam angle for very focused beams
- Very low power consumption, only 57W at full output (money saving!)
- Heavy duty bracket: can be used as floor stand and easy truss mounting
- An optional "matrix-bracket" can be used to mount 10 units in a 10x10 matrix
- Easy software updates via special software upgrade unit
- Alphanumeric LCD-display for easy menu navigation

## BEFORE USE

- Before you start using this unit, please check if there's no transportation damage. Should there be any, do not use the device and consult your dealer first.
- **Important:** This device left our factory in perfect condition and well packaged. It is absolutely necessary for the user to strictly follow the safety instructions and warnings in this user manual. Any damage caused by mishandling is not subject to warranty. The dealer will not accept responsibility for any resulting defects or problems caused by disregarding this user manual.
- Keep this booklet in a safe place for future consultation. If you sell the fixture, be sure to add this user manual.

### Check the contents:

Check that the carton contains the following items:

- Operating instructions
- LED BLINDER WHITE unit
- Bracket + knobs
- IEC power cable

## SAFETY INSTRUCTIONS:



**CAUTION**  
RISK OF ELECTRIC SHOCK  
DO NOT OPEN



**CAUTION:** To reduce the risk of electric shock, do not remove the top cover. No user-serviceable parts inside. Refer servicing to qualified service personnel only.



The lightning flash with arrowhead symbol within the equilateral triangle is intended to alert the user or the presence of un-insulated "dangerous voltage" within the product's enclosure that may be of sufficient magnitude to constitute a risk of electric shock.



The exclamation point within the equilateral triangle is intended to alert the user to the presence of important operation and maintenance (servicing) instructions in the literature accompanying this appliance.



This symbol means: indoor use only



This symbol means: Read instructions



This symbol means: Safety Class I appliance



This symbol determines: the minimum distance from lighted objects. The minimum distance between light-output and the illuminated surface must be more than 1 meters



The device is suitable for mounting on standard flammable surfaces. Standard flammable surfaces include building materials such as wood and wood-based materials more than 2mm thick.

### CAUTION: Possibly hazardous optical radiation emitted from this product.

- To protect the environment, please try to recycle the packing material as much as possible.
- A new light effect sometimes causes some unwanted smoke and/or smell. This is normal and disappears after some minutes.
- To prevent fire or shock hazard, do not expose this appliance to rain or moisture.
- To avoid condensation to be formed inside, allow the unit to adapt to the surrounding temperatures when bringing it into a warm room after transport. Condense sometimes prevents the unit from working at full performance or may even cause damages.
- This unit is for indoor use only.
- Don't place metal objects or spill liquid inside the unit. Electric shock or malfunction may result. If a foreign object enters the unit, immediately disconnect the mains power.
- Locate the fixture in a well ventilated spot, away from any flammable materials and/or liquids. The fixture must be fixed at least 50cm from surrounding walls.
- Don't cover any ventilation openings as this may result in overheating.
- Prevent use in dusty environments and clean the unit regularly.
- Keep the unit away from children.
- Inexperienced persons should not operate this device.
- Maximum save ambient temperature is 40°C. Don't use this unit at higher ambient temperatures.
- Make sure the area below the installation place is free from unwanted persons during rigging, de-rigging and servicing.
- Always unplug the unit when it is not used for a longer time or before servicing.
- The electrical installation should be carried out by qualified personal only, according to the regulations for electrical and mechanical safety in your country.
- Check that the available voltage is not higher than the one stated on the rear panel of the unit.
- The power cord should always be in perfect condition. Switch the unit immediately off when the power cord is squashed or damaged. It must be replaced by the manufacturer, its service agent or similarly qualified persons in order to avoid a hazard.
- Never let the power-cord come into contact with other cables!
- This fixture must be earthed in order to comply with safety regulations.
- Don't connect the unit to any dimmer pack.
- Always use an appropriate and certified safety cable when installing the unit.
- In order to prevent electric shock, do not open the cover. Apart from the mains fuse there are no user serviceable parts inside.
- **Never** repair a fuse or bypass the fuse holder. **Always** replace a damaged fuse with a fuse of the same type and electrical specifications!

- In the event of serious operating problems, stop using the fixture and contact your dealer immediately.
- The housing and the lenses must be replaced if they are visibly damaged.
- Please use the original packing when the device is to be transported.
- Due to safety reasons it is prohibited to make unauthorized modifications to the unit.

**Important:** Never look directly into the light source! Don't use the effect in the presence of persons suffering from epilepsy.

**DESCRIPTION:**

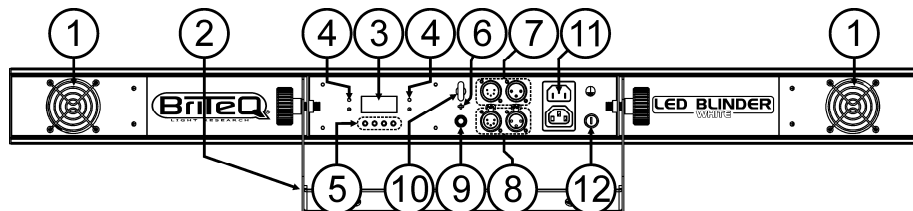

- 1. COOLING FANS:** these fans are temperature controlled so most of the time they will NOT work, this is normal! Make sure the fans are always clean and never cover the holes, this will result in possible overheating.
- 2. BRACKET:** used to hang the projector in truss (optional truss clamp needed). Also used as heavy duty floor stand for use on stage.
- 3. DISPLAY** shows the various menus and the selected functions.
- 4. LEADS:**

DMX	On	DMX input present
MASTER	On	Master mode
SLAVE	On	Slave mode
SOUND	Flashing	Sound activation

**5. BUTTONS:**

MENU	To select the programming functions
DOWN	To go backward in the selected functions
UP	To go forward in the selected functions
ENTER	To confirm the selected functions

- 6. MICROPHONE:** used to control the music activated internal programs
- 7. DMX INPUTS:** connect this input to the previous unit in the DMX chain or directly to the DMX-controller.
- 8. DMX INPUTS:** connect this input to the next unit in the DMX chain.
- 9. REMOTE CONTROL connector:** used to connect the CA-8 hand controller
- 10. SECURITY EYEBOLT:** used to secure the unit with an optional safety cable.
- 11. MAINS POWER IN/OUT:** IEC in/outputs, use the supplied IEC-cable to connect the projector to the mains. You can also daisy chain up to 10 units using the optional IEC-extension cables, available under order code 4151 (L=1m), order code 4152 (L=5m).
- 12. FUSE HOLDER:** always exchange a broken fuse with the same 20x5mm 6,3A type.

**OVERHEAD RIGGING**

- **Important:** The installation must be carried out by qualified service personal only. Improper installation can result in serious injuries and/or damage to property. Overhead rigging requires extensive experience! Working load limits should be respected, certified installation materials should be used, the installed device should be inspected regularly for safety.
- Make sure the area below the installation place is free from unwanted persons during rigging, de-rigging and servicing.
- Locate the fixture in a well ventilated spot, far away from any flammable materials and/or liquids. The fixture must be fixed at least 50cm from surrounding walls.
- The device should be installed out of reach of people and outside areas where persons may walk by or be seated.

- Before rigging make sure that the installation area can hold a minimum point load of 10times the device's weight.
- Always use a certified safety cable that can hold 12times the weight of the device when installing the unit. This secondary safety attachment should be installed in a way that no part of the installation can drop more than 20cm if the main attachment fails.
- The device should be well fixed; a free-swinging mounting is dangerous and may not be considered!
- Don't cover any ventilation openings as this may result in overheating.
- The operator has to make sure that the safety-relating and machine-technical installations are approved by an expert before using them for the first time. The installations should be inspected every year by a skilled person to be sure that safety is still optimal.

**SETUP MENU:**

Before you can operate the unit properly, you should set the right configuration via the setup menu.

- To select any of the functions, press the MENU button up to when the required one is shown on the display or use the DOWN and UP buttons to browse the menu.
- Select the function with the ENTER button (the display blinks).
- Use DOWN and UP buttons to change the mode.
- Once the required mode is selected, press the ENTER button to confirm. To go back to the main menu without any change press the MENU button shortly. The main menu is shown in the chart.

**DMX Address**

Used to set the start address in a DMX setup.

- Press the MENU button until "DMX Address" is shown on the display.
- Press the ENTER button, the display starts blinking.
- Use DOWN and UP buttons to change the DMX512 address.
- Once the correct address shows on the display, press the ENTER button to save it.

To go back to the main menu without any change press the MENU button shortly. If you want to go back to normal running mode: press the MENU button for about 2 seconds.

**Channel mode**

Used to set the desired channel setup mode.

- Press the MENU button until "Channel mode" is shown on the display.
- Press the ENTER button, the display starts blinking.
- Use DOWN and UP buttons to choose 1Chan, 12Chan, 10Chan, 2Chan or 4MSL mode.
- Once the desired channel setup mode shows on the display, press the ENTER button to save it. To go back to the main menu without any change press the MENU button shortly. If you want to go back to normal running mode: press the MENU button for about 2 seconds.

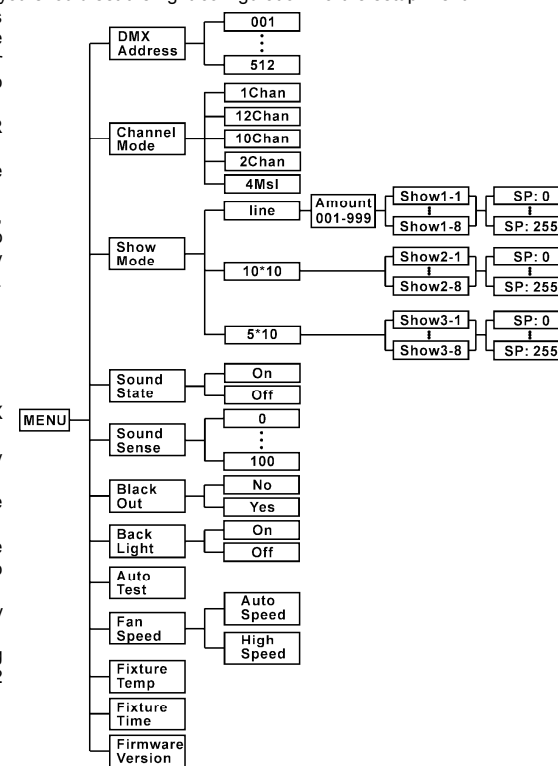

**Show Mode**

Used to choose the Show mode when used in standalone or master/slave mode.

- Press the MENU button until "Show Mode" is showing on the display.
- Press the ENTER button, the display starts blinking.
- Use DOWN and UP buttons to select one of the available shows:
  - **Line:** select this option when the unit is used in standalone or in a master/slave setup with several units placed in one line, one next to the other. Press <ENTER> to confirm.
    - You will be asked the amount of units that are linked in master/slave: set the number of linked units, including the master. Press <ENTER> to confirm.
    - You will be asked which preprogrammed show you want to use: choose from 1-1 to 1-8. Press <ENTER> to confirm. (Note that this setting is only relevant while used without any controller, you can change the speed using the menu buttons on the master)
    - You will be asked which playback speed you want for the show: choose from 0 to 255. Press <ENTER> to confirm. (Note that this setting is only relevant while used without any controller, you can change the speed using the menu buttons on the master)
  - **10 \* 10:** select this option when the unit is used in a master/slave setup with several units placed in a 10x10 matrix (10 units mounted on top of each other, using the optional matrix bracket). Press <ENTER> to confirm.
    - You will be asked which preprogrammed show you want to use: choose from 2-1 to 2-8. Press <ENTER> to confirm. (Note that this setting is only relevant while used without any controller, you can change the speed using the menu buttons on the master)
    - You will be asked which playback speed you want for the show: choose from 0 to 255. Press <ENTER> to confirm. (Note that this setting is only relevant while used without any controller, you can change the speed using the menu buttons on the master)
  - **5 \* 10:** select this option when the unit is used in a master/slave setup with several units placed in a 5x10 matrix (5 units mounted on top of each other, using the optional matrix bracket). Press <ENTER> to confirm.
    - You will be asked which preprogrammed show you want to use: choose from 3-1 to 3-8. Press <ENTER> to confirm. (Note that this setting is only relevant while used without any controller, you can change the speed using the menu buttons on the master)
    - You will be asked which playback speed you want for the show: choose from 0 to 255. Press <ENTER> to confirm. (Note that this setting is only relevant while used without any controller, you can change the speed using the menu buttons on the master)

To go back to the main menu without any change press the MENU button shortly.

If you want to go back to normal running mode: press the MENU button for about 2 seconds.

**Sound State**

The unit works to rhythm of the beat when used in standalone or master/slave mode

- Press the MENU button until "Sound State" is shown on the display.
- Press the ENTER button, the display starts blinking.
- Use DOWN and UP button to select "On" or "Off" mode.
- Once the mode is selected, press the ENTER button save it.

To go back to the main menu without any change press the MENU button shortly.

If you want to go back to normal running mode: press the MENU button for about 2 seconds.

**Sound Sense**

Used to set the sensitivity of the internal microphone

- Press the MENU button until "Sound Sense" is shown on the display.
- Press the ENTER button, the display starts blinking.
- Use DOWN and UP button to select a value between "0" (very low sensitivity) and "100" (high sensitivity).
- Once the mode is selected, press the ENTER button save it.

To go back to the main menu without any change press the MENU button shortly.

If you want to go back to normal running mode: press the MENU button for about 2 seconds.

**Blackout Mode**

**Blackout mode:** when no DMX-signal is detected, the unit goes in blackout and waits for a DMX-signal.

**No blackout mode:** when no DMX-signal is detected, the unit automatically switches to standalone mode.

- Press the MENU button until "Black Out" is shown on the display.
- Press the ENTER button, the display starts blinking.
- Use DOWN and UP button to select "Yes" (blackout on) or "No" (blackout off) mode.
- Once the mode is selected, press the ENTER button to save it.

To go back to the main menu without any change press the MENU button shortly.

If you want to go back to normal running mode: press the MENU button for about 2 seconds.

**Backlight**

**Backlight on:** display is always lit.

**Backlight off:** display is dark when not used.

- Press the MENU button until the display shows "Back Light".
- Press the ENTER button, the display starts blinking.
- Use DOWN and UP buttons to select "On" (display always lit) or "Off" (display dark when not used).
- Once the mode is selected, press the ENTER button to save it.

To go back to the main menu without any change press the MENU button shortly.

If you want to go back to normal running mode: press the MENU button for about 2 seconds.

**Auto Test**

Used to activate the internal "self-test" program which checks all possibilities of the unit.

- Press the MENU button until the display shows "Auto Test".
- Press the ENTER button to start the internal self-test program.
- To go back to the functions press the MENU button.

If you want to go back to normal running mode: press the MENU button for about 2 seconds.

**Fan Speed**

**Auto Speed:** Fans are temperature controlled, preferred mode, most of the time the unit is quiet!

**High Speed:** Fans always turn at high speed, only to be used under heavy temperature conditions.

- Press the MENU button until the display shows "Fan Speed".
- Press the ENTER button, the display starts blinking "Auto" or "High" Speed.
- Use DOWN and UP buttons to select "Auto" or "High".
- Once the mode is selected, press the ENTER button to save it.

To go back to the main menu without any change press the MENU button shortly.

If you want to go back to normal running mode: press the MENU button for about 2 seconds.

**Temperature inside the unit**

Used to show the temperature inside the unit

- Press the MENU button until the display shows "Fixture Temp".
- Press the ENTER button to show the internal temperature of the unit on the display.
- To go back to the functions press the MENU button again.

If you want to go back to normal running mode: press the MENU button for about 2 seconds.

**Fixture Hours**

Used to show the number of working hours of the unit.

- Press the MENU button until the display shows "Fixture Time".
- Press the ENTER button to show the number of working hours in the display.
- To go back to the functions press the MENU button.

If you want to go back to normal running mode: press the MENU button for about 2 seconds.

**Software version**

Used to show the software version that is installed in the unit

- Press the MENU button until the display shows "Firmware Version".
- Press the ENTER button to show the software version on the display.
- To go back to the functions press the MENU button.

If you want to go back to normal running mode: press the MENU button for about 2 seconds.

# INSTALLATION + OPERATION

**⚠ Important:** The electrical installation should be carried out by qualified personal only, according to the regulations for electrical and mechanical safety in your country.

## Electrical installation for 1 standalone unit:

- Just insert the mains cable. The unit starts working immediately in stand-alone mode.
- Remark1:** You can connect a CA-8 remote controller to the unit if you want to have more control. Refer to "how to operate the unit" to learn how to do this.
- Remark2:** if there's no output, please make sure to set the unit in master mode and set the blackout mode to "NO" and Sound State to "On" (see previous chapter)

## Electrical installation for two or more units in master/slave:

In this mode the units will show a synchronized show, working to the rhythm of the beat.

- Connect 2 to maximum 999 units together using good quality balanced microphone cables. The first unit in the chain will automatically act as the master, the other units will act automatically as slaves.
- Make sure that all units are connected to the mains.
- Done!

**Remark:** You can connect a CA-8 remote controller to the master unit if you want to have more control over the master/slave operation

**Remark2:** if there's no output, please make sure to set the first unit in master mode and set the blackout mode to "NO" and Sound State to "On" (see previous chapter)

**Remark3:** please note that linking of the mains power input is limited to 10 units.

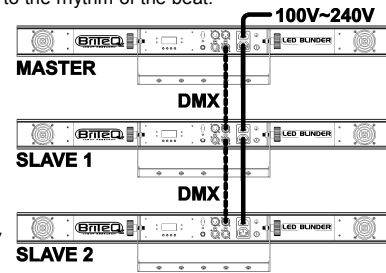

## Electrical installation for two or more units in 4MSL DMX-master/slave:

In this mode the units will show a synchronized show, eventually working to the rhythm of the beat but you can still control some functions on the master by 4 DMX-channels.

- To assure proper operation you need an optional "Mini DMX-SPLITTER" to isolate the master/slave line from the main DMX-line, see drawing.
- Connect 2 to maximum 999 units together using good quality balanced microphone cables. The first unit in the chain will act as the master, the other units will act automatically as slaves.
- Set the master to 4MSL channel mode (see previous chapter). Check the DMX-chart below to see the controllable functions.
- For the DMX-controller the master and his slaves can now be considered as 1 virtual effect that needs a start address so it can be controlled as any other DMX-unit in the DMX chain: see "DMX Address" in the chapter "Main Menu" to see how you can set the DMX-start address.
- Make sure that all units are connected to the mains.
- Set the DMX-controller according to the DMX-chart below.
- Done!

**Remark:** in order to work well to the rhythm of the music, make sure that the option "Sound State" on the master is set to "On" (see previous chapter)

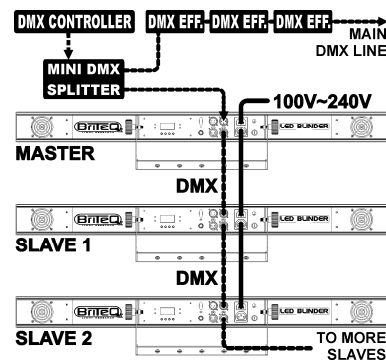

## DMX-Chart for 4MSL working mode

4MSL mode			
CH 1	CH 2	CH 3	CH 4
Chase	Chase Speed	Strobe	Dimmer
248-255	Random Chase	248-255	
218-247	Chase 8	247	
188-217	Chase 7	Fast	
158-187	Chase 6	⚡⚡⚡	
128-157	Chase 5	8-255	
98-127	Chase 4	⚡	
68-97	Chase 3	Slow	
38-67	Chase 2	0-7	
0-37	Chase 1	Open	
0-7	Full On	0	

## Electrical installation in DMX-mode:

- The DMX-protocol is a widely used high speed signal to control intelligent light equipment. You need to "daisy chain" your DMX controller and all the connected units with a good quality balanced cable.
- Both XLR-3pin and XLR-5pin connectors are used, however XLR-3pin is more popular because these cables are compatible with balanced audio cables.  
Pin layout XLR-3pin: Pin1 = GND ~ Pin2 = Negative signal (-) ~ Pin3 = Positive signal (+)  
Pin layout XLR-5pin: Pin1 = GND ~ Pin2 = Negative signal (-) ~ Pin3 = Positive signal (+) ~ Pins4+5 not used.
- To prevent strange behavior of the light effects, due to interferences, you must use a 90Ω to 120Ω terminator at the end of the chain. Never use Y-splitter cables, this simply won't work!
- Make sure that all units are connected to the mains.
- Each light effect in the chain needs to have its proper starting address so it knows which commands from the controller it has to decode. In the next section you will learn how to set the DMX addresses.

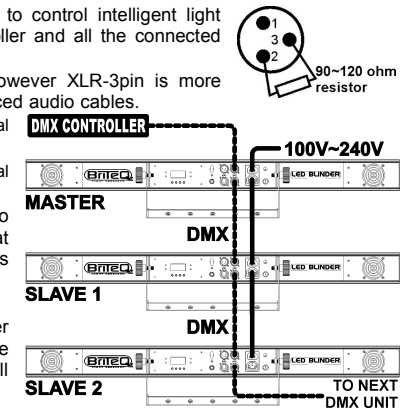

## HOW TO SET THE RIGHT START ADDRESS:

Refer to the previous chapter (DMX-512 address setting) to learn how to set the starting address on this unit. The starting address of each unit is very important. Unfortunately it is impossible to tell you in this user manual which starting addresses you have to set because this completely depends on the selected channel mode and on the controller you will use. So please refer to the user manual of your DMX-controller to find out which starting addresses you must set.

**DMX-CONFIGURATIONS:**

Apart from the DMX Master/slave mode (4MSL) there are also 4 other DMX-channel modes that you can choose of. (see chapter "setup menu", option "channel mode") The desired DMX-channel mode depends on how much control you need:

**1channel and 2channel modes are simple channel modes with limited DMX-control:**

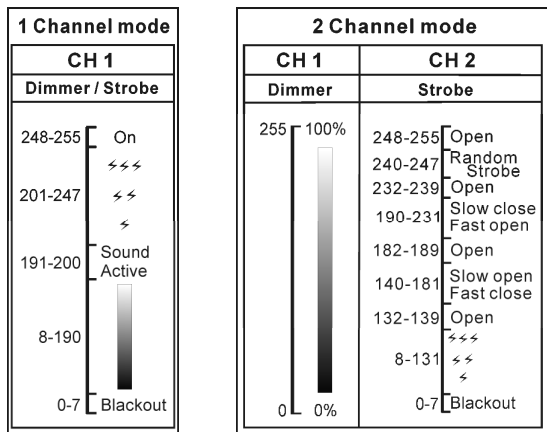

**With 10channel and 12channel modes channel modes you have full DMX-control over all 10 clusters:**

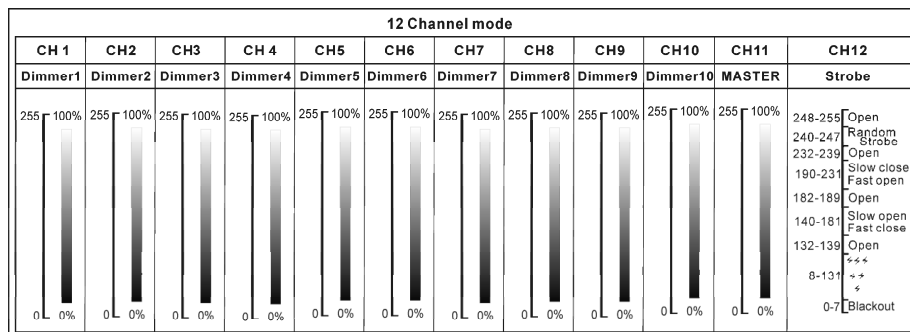
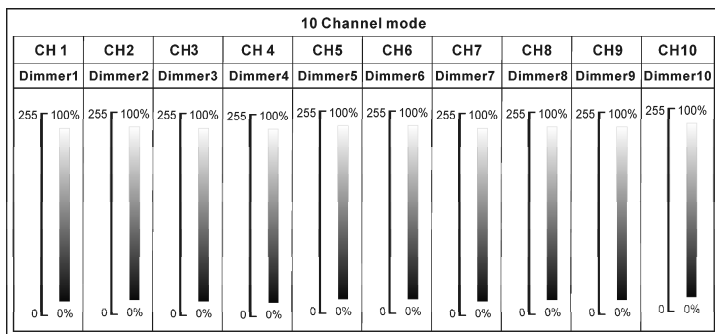

**OPERATE THE UNIT BY CA8 HAND CONTROLLER**

When used in standalone or master/slave mode we strongly advise you to use the CA-8 "Wired easy controller": connect the controller to the jack input of the first unit (master).

Now you can control all the connected units:

**STANDBY BUTTON:**

Press this button to start/stop blackout mode on all connected units.

**MODE/FUNCTION BUTTONS:**

With the MODE button you can select 3 different modes:

- **The LED is off:** with the FUNCTION button you can select different strobe modes, like "sound strobe".
- **The LED is blinking slowly:** with the FUNCTION button you can select different shows.
- **The LED is blinking fast:** with the FUNCTION button you can select different speeds.

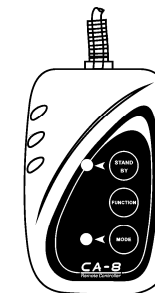

**MAINTENANCE**

- Make sure the area below the installation place is free from unwanted persons during servicing.
- Switch off the unit, unplug the mains cable and wait until the unit has been cooled down.
- **During inspection the following points should be checked:**
  - All installing screws and any of its parts should be tightly fastened and may not be corroded.
  - Housings, fixations and installations spots (ceiling, truss, suspensions) should be free from deformation.
  - When an optical lens is visibly damaged due to cracks or deep scratches, it must be replaced.
  - The mains cables must be in impeccable condition and should be replaced immediately when even a small problem is detected.
  - To protect the device from overheat the cooling fans and ventilation openings should be cleaned monthly.
  - The interior of the device should be cleaned annually using a vacuum cleaner or air-jet.
  - The cleaning of internal and external optical lenses and/or mirrors must be carried out periodically to optimize light output. Cleaning frequency depends on the environment in which the fixture operates: damp, smoky or particularly dirty surroundings can cause greater accumulation of dirt on the unit's optics.
    - Clean with a soft cloth using normal glass cleaning products and always dry the parts carefully.
    - Clean the external optics at least once every 30 days.
    - Clean the internal optics at least every 90 days.

**Attention:** We strongly recommend internal cleaning to be carried out by qualified personnel!

**SPECIFICATIONS**

- Mains Input:** AC 100 ~ 240V, 50/60Hz
- Power consumption:** 57 Watt max.
- Power daisy chaining qty:** +/- 10 units
- Fuse:** 250V 6,3A slow blow (20mm glass)
- Sound Control:** Internal microphone
- DMX connections:** 3pin + 5pin XLR male / female
- DMX channels used:** 1+2+10+12channels + special 4MSL
- Lamp:** 40pcs 1W LEDs (10clusters, each with 4pcs 1W LEDs) see drawing
- Size:** 7,2kg
- Weight:** 7,2kg

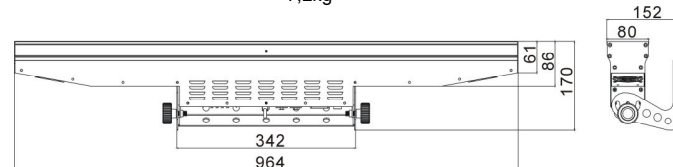

Every information is subject to change without prior notice  
You can download the latest version of this user manual on our website: [www.beglec.com](http://www.beglec.com)