

LED EXPO BEAM

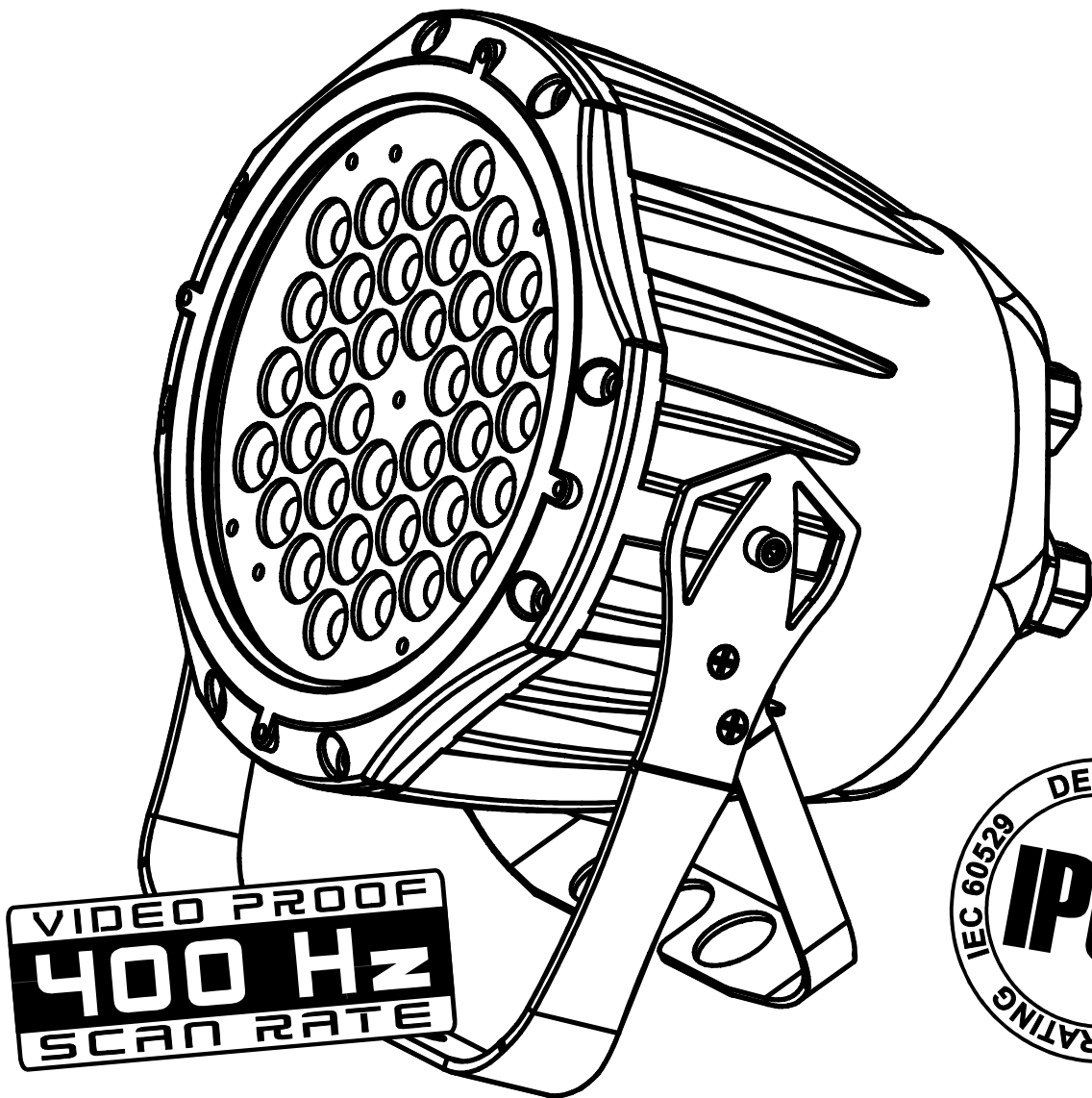

USER
MANUAL
Ver 1,0



WWW.BRITEQ-LIGHTING.COM

T ABLE OF CONTENTS

PART 1 PRODUCT (GENERAL)	1.
1.1-- <i>PRODUCT INTRODUCTION</i>	1.
1.2-- <i>PRODUCT FEATURES</i>	1.
1.3-- <i>TECHNICAL SPECIFICATIONS</i>	2.
1.4-- <i>PHOTOMETRIC DATA</i>	3.
1.5-- <i>SAFETY WARNING</i>	3.
PART 2 INSTALLATION	4.
2.1-- <i>MOUNTING</i>	4.
2.2-- <i>POWER CONNECTION</i>	4.
2.3-- <i>SETTING UP WITH A DMX512 CONTROLLER</i>	5.
2.3-1-- <i>DMX512 ADDRESSING WITHOUT ID ADDRESSING</i>	5.
2.3-2-- <i>DMX512 ADDRESSING WITH ID ADDRESS</i>	5.
PART 3 DISPLAY PANEL OPERATION	7.
3.1-- <i>BASIC</i>	7.
3.2-- <i>MENU</i>	7.
3.3-- <i>EDIT STATIC COLOUR</i>	8.
3.4-- <i>DMX512 SETTINGS</i>	8.
3.5-- <i>RUN MODE</i>	8.
3.6-- <i>PERSONALITY</i>	8.
3.7-- <i>ID ADDRESS</i>	9.
3.8-- <i>SPECIAL SETTINGS</i>	9.
3.9-- <i>ACTIVATE THE PASSWORD</i>	9.
3.10-- <i>WHITES SETTING</i>	9.
PART 4 USING A DMX512 CONTROLLER	10.
4.1-- <i>BASIC ADDRESSING</i>	10.
4.2-- <i>CHANNEL ASSIGNMENT</i>	10.
4.3-- <i>BASIC INSTRUCTIONS FOR DMX512 OPERATION</i>	12.
PART 5 APPENDIX	13.
5.1-- <i>TROUBLE SHOOTING</i>	13.
5.2-- <i>MAINTENANCE</i>	14.

1 PRODUCT (GENERAL)

1.1 PRODUCT INTRODUCTION

This product is designed for indoor or outdoor use. Suitable applications include wash or effect lighting for architectural, stage or nightclub applications. This product can also be installed for use in signage and advertising using the dynamic functions available with DMX512 control. Direct input of DMX512 signal allows the units to be controlled from any DMX512 controller. This product can be operated as a single unit or in multiple units for large applications.

1.2 PRODUCT FEATURES

LED FIXTURE

- * Dimmer 0-100%
- * Strobe
- * IP65 protection rating
- * LED display
- * Display control 'lock-out'
- * Direct DMX512 input
- * Independent ID address
- * Lightweight aluminium casing
- * Different white colors setting

1.3 TECHNICAL SPECIFICATIONS

LED MODULE

LED MODULE:	
Voltage	100~240V...50/60Hz
Rated Power	50W
IP	IP65 protection rating
LED/Unit	36pcs (28 xWhite / 8 x Amber)
Output/LED	1W
Environment Temperature	-20°C~40°C
Cooling	Direct air convection
Dimensions	235 x 165x 300mm
Weight	4Kg

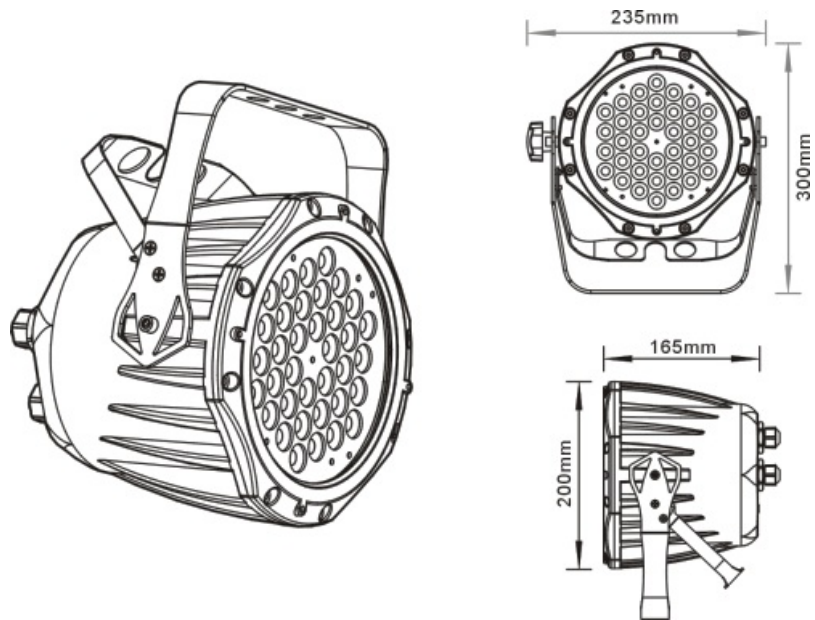

1.4 PHOTOMETRIC DATA

WHITE

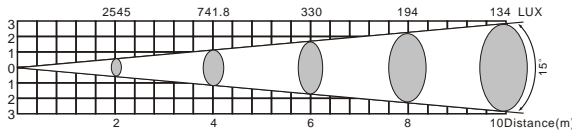

AMBER

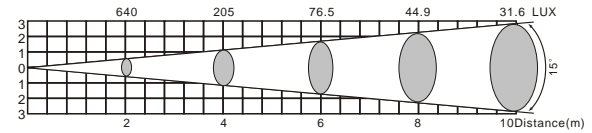

WHITE+AMBER

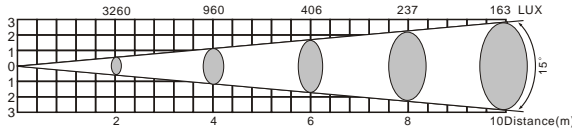

1.5 SAFETY WARNING

IMPORTANT

**【ALWAYS READ THE USER MANUAL BEFORE OPERATION. 】
【PLEASE CONFIRM THAT THE POWER SUPPLY STATED ON THE
PRODUCT IS THE SAME AS THE MAINS POWER SUPPLY IN YOUR
AREA.】**

- This product must be installed by a qualified professional.
- Always operate the equipment as described in the user manual.
- A minimum distance of 0.5m must be maintained between the equipment and combustible surface.
- The product must always be placed in a well ventilated area.
- Always make sure that the equipment is installed securely.
- DO NOT stand close to the equipment and stare directly into the LED light source.
- Always disconnect the power supply before attempting and maintenance.
- Always make sure that the supporting structure is solid and can support the combined weight of the products.
- The earth wire must always be connected to the ground.
- Do not touch the power cables if your hands are wet.

ATTENTION



- This product left the place of manufacture in perfect condition. In order to maintain this condition and for safe operation, the user must always follow the instructions and safety warnings described in this user manual.
- Avoid shaking or strong impacts to any part of the equipment.
- Make sure that all parts of the equipment are kept clean and free of dust.
- Always make sure that the power connections are connected correct and secure.
- If there is any malfunction of the equipment, contact your distributor immediately.
- When transferring the product, it is advisable to use the original packaging in which the product left the factory.
- Shields, lenses or ultraviolet screens shall be changed if they have become damaged to such an extent that their effectiveness is impaired.
- The lamp (LED) shall be changed if it has become damaged or thermally deformed.

2 INSTALLATION

2.1 MOUNTING

HANGING

The LED PAR can be mounted in a hanging position using the supporting bracket. The bracket should be secured to the mounting truss or structure using a standard mounting clamp. Please note that when hanging the unit a safety cable should also be used.

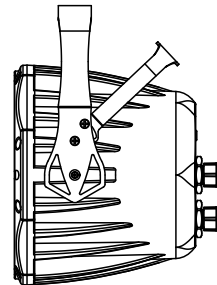

UPRIGHT

The LED PAR can be mounted in an upright or sitting position using the supporting brackets.

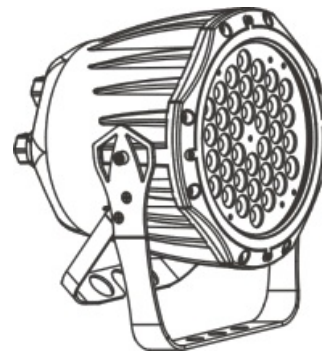

The LED MODULE can be mounted at any angle and in any position. It is possible to further adjust the angle of the LED MODULE using the two adjustment knobs located on the side of the fixture.

2.2 POWER CONNECTIONS

@ 220V: 50 units may be connected in series

@ 120V: 25 units may be connected in series

Note: As this fixture's DMX signal cable connection is Parallel connection, so if over 20 units to be connected, then a DMX signal amplifier is needed.

2.3 SETTING UP WITH A DMX512 CONTROLLER

2.3-1 **DMX512 ADDRESSING WITHOUT ID ADDRESSING (STUDIO 2 MODE)**

- Connect the DMX512 controller to the units in series.
- Each unit has 6 DMX channels so the DMX Addresses should increase by increments of 6 (e.g. 1,7,13,19...)
- The ID address has not been set so therefore when using the controller CH8 must be inactive (CH6=0).
- It is also possible to deactivate ID address selecting **[ID OFF]** from the **[Settings]** menu on the fixture
- Each DMX Address may be used as many times as required.
- Any DMX address in the range from 001 to 512 may be used.

Example:

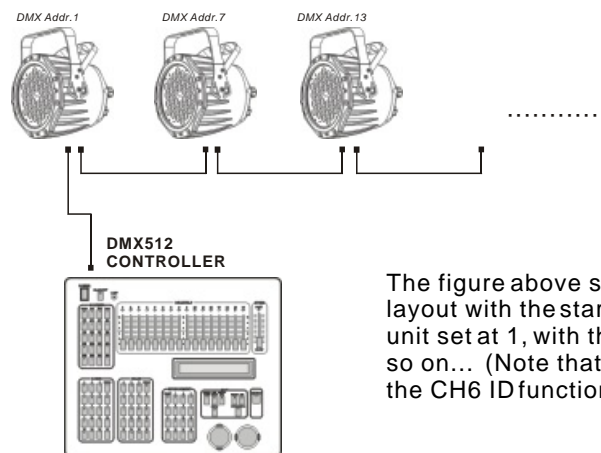

The figure above shows a simple DMX512 layout with the starting address of the first unit set at 1, with the second set at 7 and so on... (Note that when used in this way, the CH6 ID function must be inactive (CH6=0))

2.3-2 **DMX512 ADDRESSING WITH ID ADDRESS (STUDIO 2 MODE)**

- Connect the DMX512 controller to the units in series
- Each unit has 6 DMX channels so the DMX Addresses should increase by increments of 6 (e.g. 1,7,13,19...)
- Each DMX Address may be used as many times as required.
- Any DMX address in the range from 001 to 512 may be used.
- Each DMX address may carry up to 66 separate ID addresses.
- **[ID]** should be set in the menu on each unit in ascending values (i.e. 1,2,3...)
- **[ID On]** should be set in the **[Settings]** menu on each unit.
- ID addresses are accessible from CH6 on the DMX512 controller.

Example:

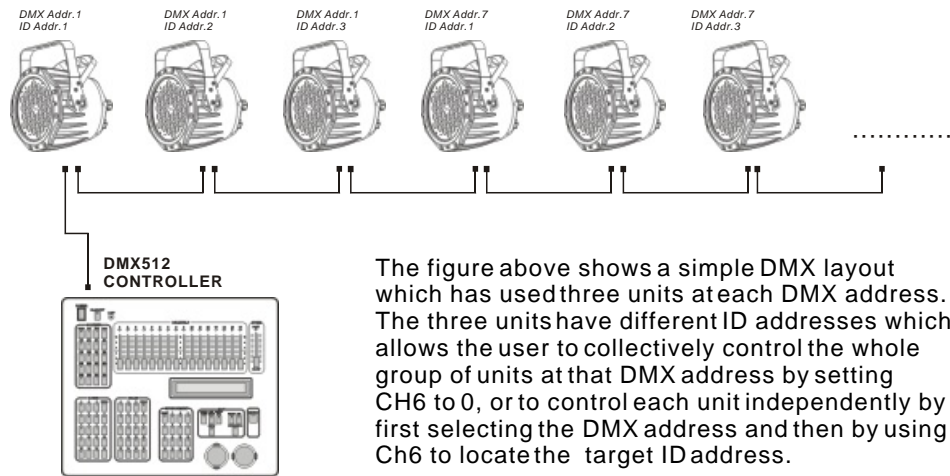

The figure above shows a simple DMX layout which has used three units at each DMX address. The three units have different ID addresses which allows the user to collectively control the whole group of units at that DMX address by setting CH6 to 0, or to control each unit independently by first selecting the DMX address and then by using Ch6 to locate the target ID address.

3 DISPLAY PANEL OPERATION

3.1 BASIC

The LED fixture is mounted with a LCD display and 4 control buttons.

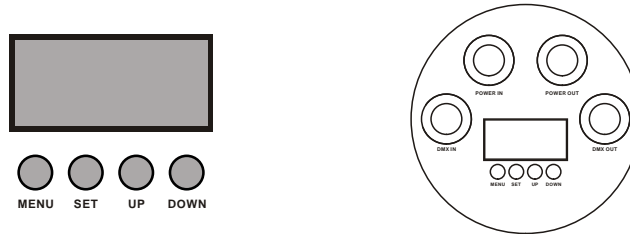

【MENU】 scroll through the main menu or return to the main menu

【 SET 】 enter the currently selected menu or confirm the current function value

【 UP 】 scroll 'UP' through the menu list or increase the value of the current function

【DOWN】 scroll 'DOWN' through the menu list or decrease the value of the current function

3.2 MENU

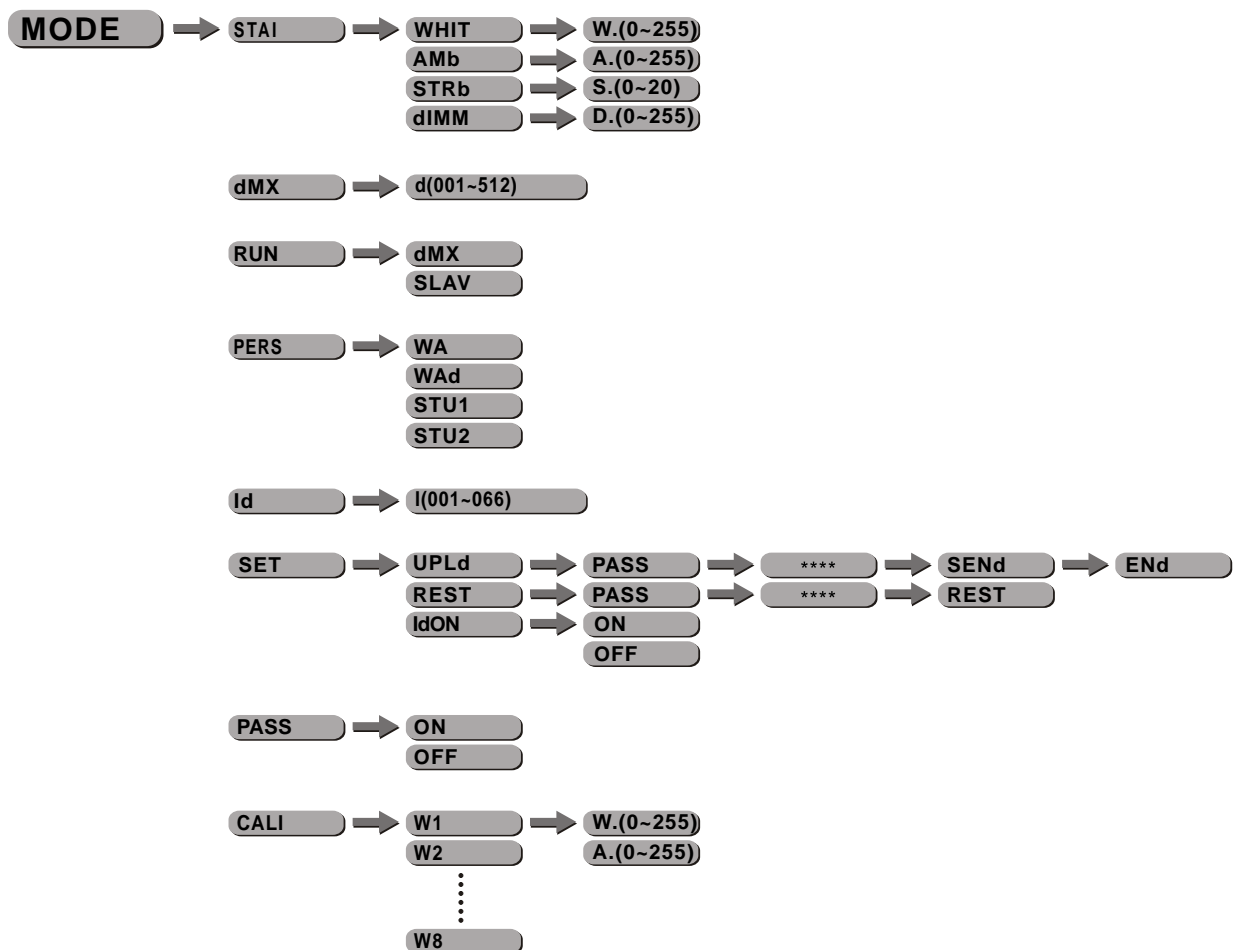

3.3 EDIT STATIC COLOUR

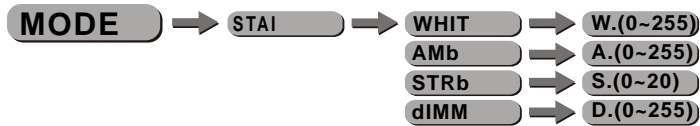

【STATIC COLOUR】

- Combine **【White】** , **【Amber】** ,and **【Dimmer】** to create whites with different color temperature
- Set the value of the **【Strobe】** (0-20Hz)

3.4 DMX512 SETTINGS



【DMX】

- Enter the **【DMX】** mode to set the DMX ADDRESS.

3.5 RUN MODE



【RUN MODE】

- Enter the **【RUN MODE】** mode to set working mode.
- **【DMX】** mode is for using the DMX512 controller to control the fixtures.
- **【SLAVE】** mode is for Master -- Slave operation, or controlled fixture by Pix-controller.

Note: When fixtures are under Auto program operation, the **【RUN MODE】** does not work.

3.6 PERSONALITY

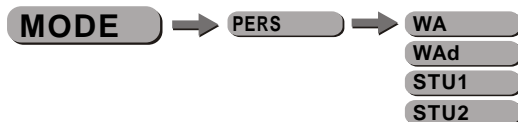

【PERSONALITY】

- Enter the **【PERSONALITY】** mode to select DMX mode: **【WA】** , **【WA+D】** , **【STUDIO 1】** ,or **【STUDIO 2】** .

3.7 ID ADDRESS



【ID】

- Enter the **【ID】** mode to set the ID ADDRESS.

3.8 SPECIAL SETTINGS

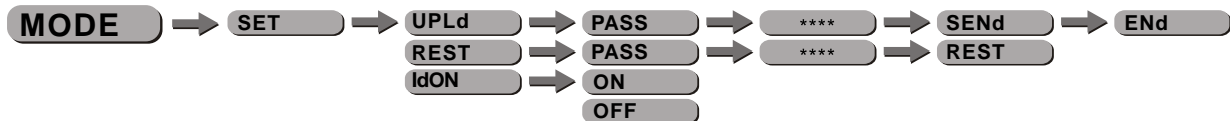

【SETTING】

- Select **【Upload】** to upload the custom programs from the current MASTER unit to the SLAVE units.
- In order to activate the upload function the password must be entered.
- Password is the same as the main access password.
- When uploading the MASTER and SLAVE units will be full on..
- If an error occurs when uploading the MASTER and/or SLAVE units will display AMBER.
- On successful uploading of the custom programs the MASTER and SLAVE units will display WHITE.
- In order to reset custom modes to default values select **【PESET Parameter】**.
- Enter **【ID ON/OFF】** in order to allow/disallow ID address function from the DMX512 controller.

3.9 ACTIVATE THE PASSWORD

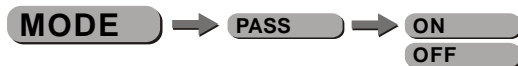

【KEYLOCK】

- Enter the **【KEYLOCK】** mode to select whether the access password is on or off.
- In order to enter access password it is necessary to first press **【SET】**.
- Access password is **【UP】 + 【DOWN】 + 【UP】 + 【DOWN】**.

3.10 WHITES SETTING

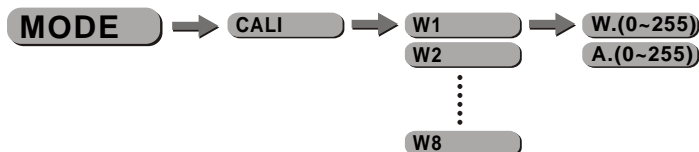

【CALIB】

- Enter the **【CALIB】** to select white color of different color temperature.
- There are 8 pre-programmed White colors can be edited by using **【White】** & **【Amber】**.

4 USING A DMX512 CONTROLLER

4.1 BASIC ADDRESSING

- Connect all of the units in series using standard DMX512 signal cable or the IP65 rated cable provided.
- Set the DMX512 address in the **【DMX】** menu.
- It is possible to have the same DMX address or independent addresses for each fixture.

4.2 CHANNEL ASSIGNMENT

- Note: This product have four DMX512 channel configuration: **【WA】**, **【WA+D】**, **【STUDIO 1】** and **【STUDIO 2】**

WA

CHANNEL	VALUE	FUNCTION
1	0 ↔ 255	WHITE
2	0 ↔ 255	AMBER

WA+D

CHANNEL	VALUE	FUNCTION
1	0 ↔ 255	MASTER DIMMER
2	0 ↔ 255	WHITE
3	0 ↔ 255	AMBER

STUDIO 1

CHANNEL	VALUE	FUNCTION
1	0 ↔ 255	MASTER DIMMER
2	0 ↔ 255	SAME AS 【STUDIO 2】 CH4

STUDIO 2

CHANNEL	VALUE	FUNCTION
1	0 ↔ 255	MASTER DIMMER
2	0 ↔ 255	WHITE
3	0 ↔ 255	AMBER
4	0 ↔ 10	DIFFERENT WHITES NO FUNCTION
	11 ↔ 40	WHITE 1: 2800K
	41 ↔ 70	WHITE 2: 3000K
	71 ↔ 100	WHITE 3: 3200K
	101 ↔ 130	WHITE 4: 3400K
	131 ↔ 160	WHITE 5: 4200K
	161 ↔ 190	WHITE 6: 4900K
	191 ↔ 220	WHITE 7: 5600K
	221 ↔ 255	WHITE 8: 5900K
5	0 ↔ 9	STROBE NO FUNCTION
	10 ↔ 255	1~20Hz
6	0 ↔ 9	ID ADDRESS ID1-ID66
	10 ↔ 19	ID1
	20 ↔ 29	ID2
	30 ↔ 39	ID3
	40 ↔ 49	ID4
	50 ↔ 59	ID5
	60 ↔ 69	ID6
	70 ↔ 79	ID7
	80 ↔ 89	ID8
	90 ↔ 99	ID9
	100 ↔ 109	ID10
	110 ↔ 119	ID11
	120 ↔ 129	ID12
	130 ↔ 139	ID13
	140 ↔ 149	ID14
	150 ↔ 159	ID15
	160 ↔ 169	ID16
	170 ↔ 179	ID17
	180 ↔ 189	ID18
	190 ↔ 199	ID19
	200 ↔ 209	ID20
	210	ID21
	⋮	⋮
	255	ID66

4.3 BASIC INSTRUCTIONS FOR DMX512 OPERATION (STUDIO 2)

MASTER DIMMER

- CH1 controls the intensity of the currently projected color
- When the slider is at the highest position (255) the intensity of the output is the maximum

WHITE & AMBER SELECTION

- CH2 and CH3 control the intensity ratio of each of the WHITE & AMBER LEDs.
- When the slider is at the highest position (255) the intensity of the color is the maximum.
- CH2 and CH3 can be combined together to create whites with different color temperature.

STROBE

- CH 5 controls the strobe of CH1 to CH4
- CH5 has priority over CH2, CH3 & CH4.

DIFFERENT WHITES

- Ch4 allow user to select 8 whites with different color temperature.
- The 8 whites are take from the **【CALIB】** on Display panel.

ID ADDRESS SELECTION

- CH6 is used to select the target ID address.
- Each independent DMX address may have upto 66 independent ID addresses.
- An ID address of 0 will activate all ID address locations.

5 APPENDIX

5.1 TROUBLE SHOOTING

SITUATION	CAUSE	ACTION
No display	1) No power input 2) Power connection error 3) Display damaged 4) Display board IC error, or power input connection error, or two board connection error	1) Check power supply 2) Check power connection 3) Replace display 4) Check the IC and all the connections
Display normal, but no response from buttons	1) Buttons damaged 2) Main PCB damaged	1) Replace buttons 2) Replace Main PCB
Display normal, but no response from buttons	1) Signal Cable error 2) Signal connection error 3) The input signal IC damaged 4) DMX address error	1) Check all signal Cables 2) Check all signal connections 3) Check the input signal IC 4) Check DMX address
Color mixing uneven, with splash	1) LED not joining well 2) Lens not installing well	1) Check LEDs joining 2) Check lens installing
LEDs of the same color are not lit	1) LED damaged 2) LED damaged or Main PCB	1) Replace LEDs 2) Replace damaged LED or Main PCB
Manual and program can not save or display error	1) Saving IC damaged	1) Replace saving IC

5.2 MAINTENANCE

No	ITEM
1	Gel holder
2	Upper cover
3	Glass plate
4	LED heat-transfer plate
5	Power supply
6	Display board
7	Casing
8	Driver board
9	Secondary support
10	Main support

